

RAY FS MT | VERTICAL 415-418

FLOW SENSOR | MECHANICAL

HYDROMETER



APPLICATION

Volume measuring component for measuring heat for billing hot water consumption.

FEATURES

- ▶ Multi-jet impeller meters designed to the latest technical standards with completely dry running operation and magnetic coupling
- ▶ The roller counter is dustproof and condensation-proof and can be rotated for easier reading
- ▶ For installation in rising pipes and downpipes
- ▶ The built-in pulse transmitter is cast in a waterproof enclosure and is easily replaceable
- ▶ The pulse transmitter for volume measuring components is fitted with a 100 Ω , ¼ W protective resistor (cable length 3 m)
- ▶ Facility for remote transmission of flow rates
- ▶ The compact design in subassemblies simplifies maintenance and repair
- ▶ Only the impeller operates in the wet chamber to prevent faults due to sediment
- ▶ The meters are equipped with a sealed shield for protection against magnetic interference

RAY FS MT | VERTICAL 415-418

FLOW SENSOR | MECHANICAL

GENERAL

RAY FS MT VERTICAL 415-418		
Medium temperature range	°C	0 ... 120
Nominal pressure	PN bar	16
Display range		0.05 l ... 100,000 m ³
Pulse value	l/pulse	1 / 10 / 100 (other pulse rates on request)
Bearing		Carbide or plastic
Approval		National 22.16 / 82.10
Metrological class		A•H
Protection class		IP 65

TECHNICAL DATA

Nominal diameter	DN	mm	20	20	20	25	25
Nominal flow rate	Q _n	m ³ /h	1	1.5	2.5	3.5	3.5
Overall length	L	mm	105	105	105	135	150
Maximum flow rate (short-term)	Q _{max}	m ³ /h	2	3	5	7	7
Transition flow rate	Q _t	l/h	100	150	250	350	350
Minimum flow rate	Q _{min}	l/h	25	30	50	65	65
Starting flow rate		l/h	10	12	19	25	25
Flow rate at 0.1 bar pressure loss ¹		m ³ /h	0.6	1	1.6	2.2	2.2
Flow rate at 0.1 bar pressure loss ²		m ³ /h	-	1.2	1.8	2.5	2.2
Flow resistance coefficient Zeta			72.4	26.1	10.2	13.1	13.1

Nominal diameter	DN	mm	25	25	40	40
Nominal flow rate	Q _n	m ³ /h	6	6	10	10
Overall length	L	mm	135	150	150	200
Maximum flow rate (short-term)	Q _{max}	m ³ /h	12	12	20	20
Transition flow rate	Q _t	l/h	600	600	1000	1000
Minimum flow rate	Q _{min}	l/h	90	90	160	160
Starting flow rate		l/h	35	35	60	60
Flow rate at 0.1 bar pressure loss ¹		m ³ /h	3.8	3.8	6.3	6.3
Flow rate at 0.1 bar pressure loss ²		m ³ /h	2.4	2.4	6.3	6.3
Flow resistance coefficient Zeta			4.4	4.4	10.5	10.5

¹ Rising pipe

² Downpipe

RAY FS MT | VERTICAL 415-418

FLOW SENSOR | MECHANICAL

DIMENSIONS

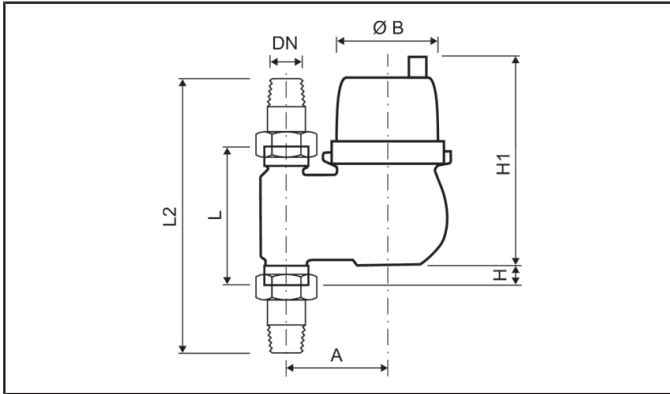

Nominal diameter	DN	mm	20	20	20	25	25
Nominal flow rate	Q _n	m ³ /h	1	1.5	2.5	3.5	3.5
Overall length	L	mm	105	105	105	135	150
Overall length with coupling	L2	mm	203	203	203	253	268
Connection thread on meter		Inch	G1B	G1B	G1B	G1¼B	G1¼B
Connection thread of coupling		Inch	R¾	R¾	R¾	R1	R1
Height	H	mm	14	14	14	31	31
Height	H1	mm	180	180	180	191	191
Diameter	Ø B	mm	96	96	96	102	102
Width	A	mm	82	82	82	95	95
Weight without coupling		kg	2.2	2.1	2.1	3.1	3.1
Weight with coupling		kg	2.5	2.4	2.4	3.7	3.7

Nominal diameter	DN	mm	25	25	40	40
Nominal flow rate	Q _n	m ³ /h	6	6	10	10
Overall length	L	mm	135	150	150	200
Overall length with coupling	L2	mm	253	268	288	338
Connection thread on meter		Inch	G1¼B	G1¼B	G2B	G2B
Connection thread of coupling		Inch	R1	R1	R1½	R1½
Height	H	mm	31	31	21	21
Height	H1	mm	191	191	221	221
Diameter	Ø B	mm	102	102	130	130
Width	A	mm	95	95	120	120
Weight without coupling		kg	3.1	3.1	5.5	5.5
Weight with coupling		kg	3.7	3.7	6.7	6.7

NOTE

When using the contact water meters as volume measuring component, we recommend that the meters are selected so that the pressure loss of 0.1 bar is not exceeded at maximum load.

Order the pulse output without resistor for a low-resistance load, e.g. mechanical roller counters.

RAY FS MT | VERTICAL 415-418

FLOW SENSOR | MECHANICAL

PRESSURE LOSS GRAPH

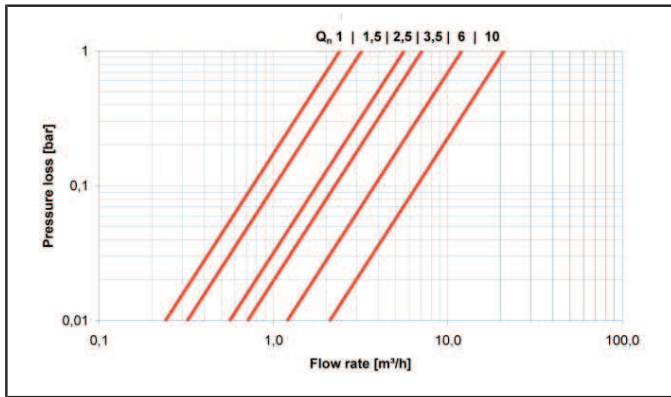

Rising pipe

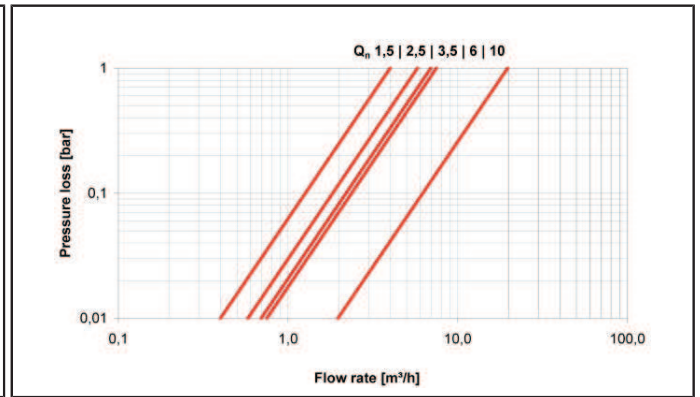

Downpipe

TYPICAL ERROR GRAPH

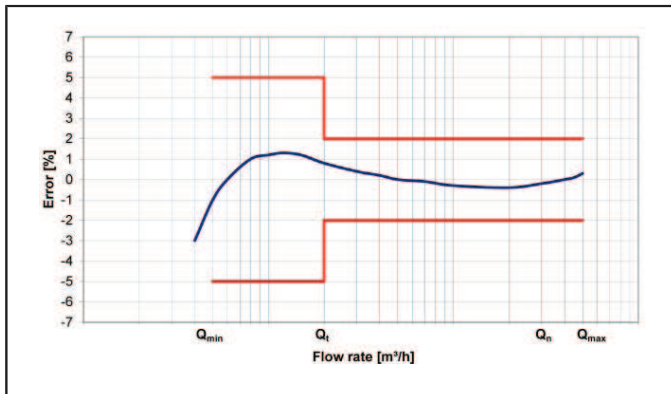

Typical error graph

HYDROMETER

HYDROMETER GmbH · Postfach 1462 · 91505 Ansbach
 Tel. +49 981 1806-0 · Fax: +49 981 1806-615 · info@hydrometer.de · www.hydrometer.de
 Subject to technical adjustments

 smart in solutions